

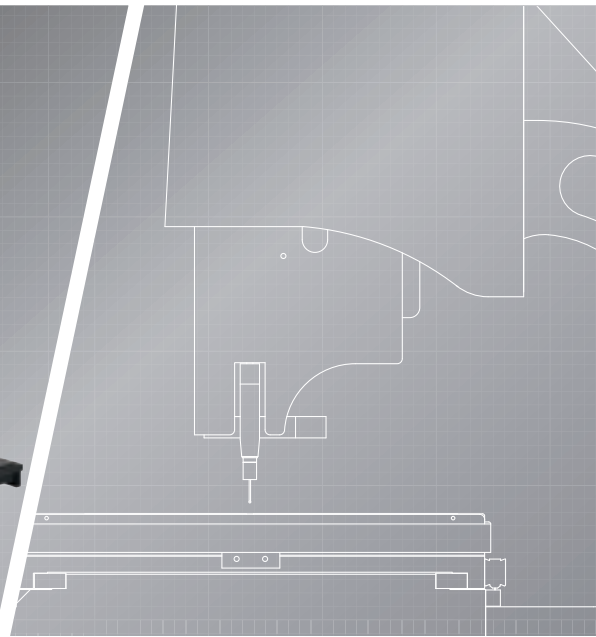

*PARTNERS IN PRECISION*

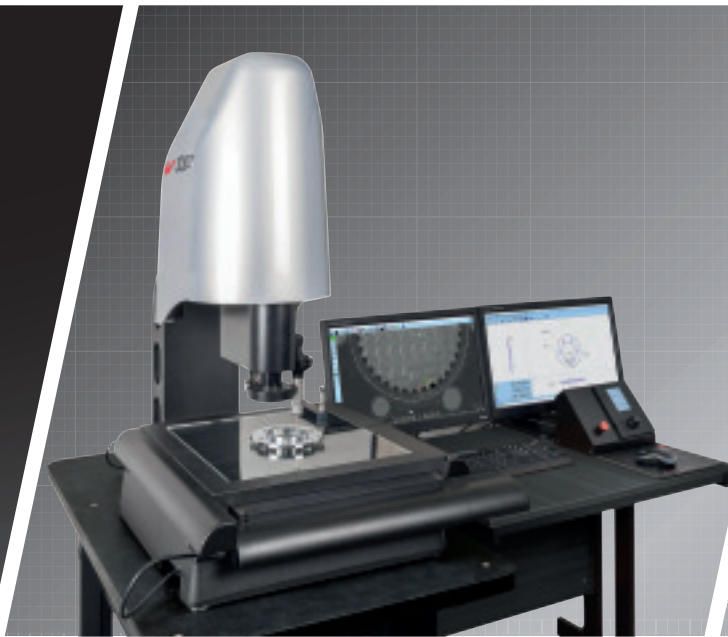

***OPTICAL INSTRUMENTS***  
*VISION SYSTEMS*

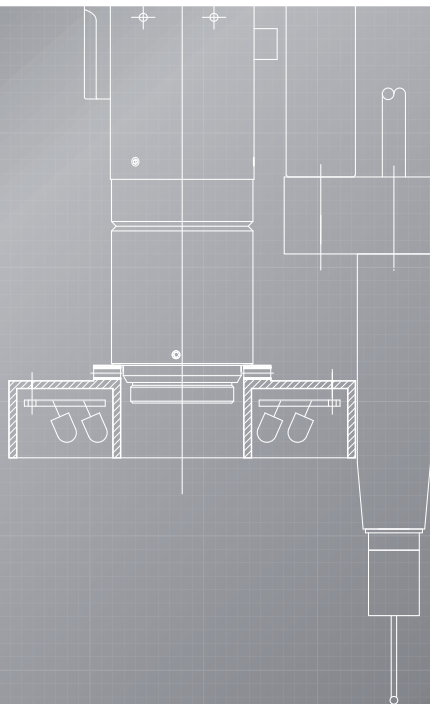

Page No.



Page 3

## Vision Systems

Baty Vision Systems - VuMaster 2D Manual / 2D CNC	3
Baty Vision Systems - Venture Touch	4
Baty Vision Systems - Venture 3D CNC	5
Baty Options & Accessories - Profile Projector	6
Baty Vision Systems - Venture Plus	7-8

## Software

Fusion Software	9-10
-----------------	------

## Fixtures

Flexmaster Fixtures	11
---------------------	----



Page 4

## Technical Specification

Baty Vision Systems - Technical Specification	12
---	----

## Casting Materials

Reprorubber - Metrology Grade Casting Material	13-14
--	-------

## Notes

15



Pages 9-10

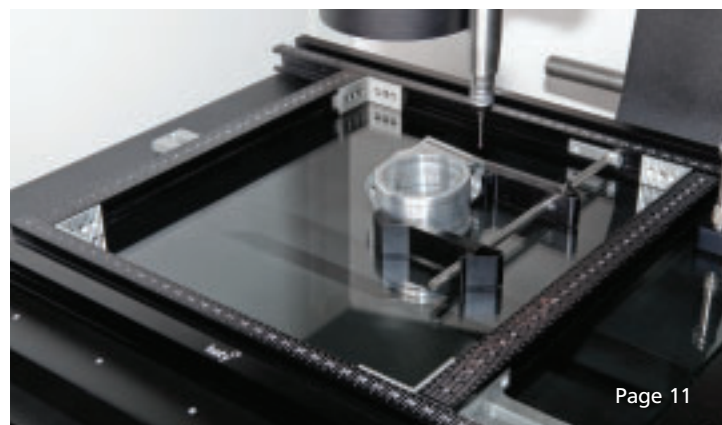

Page 11

## Baty Vision Systems - VuMaster 2D Manual / 2D CNC

The BATY VuMaster is a 2D vision system with a massive difference.

Due to its innovative absolute 2D scale system, the newly designed VuMaster does not have a conventional moving stage or encoders - just a floating measuring camera that moves anywhere in the measuring range. The result is fast, accurate, 'non contact' measurement over a much larger measuring range - 400mm x 300mm.

Because the camera moves and the part stays still, there is often no need for expensive and time consuming work holding devices.

VuMaster is either operated manually or inspection routines can be recorded and stored. When played back, these 'programs' either run automatically, (CNC), or guide the operator through a pre-defined inspection procedure recreating the same lighting conditions and using 'Video Edge Detection' to automatically 'capture' feature data.

Finally, a report is generated in the form of a fully dimensioned drawing of the measured part.

### Features

- Large 400mm x 300mm measuring range
- Sturdy construction with a granite base
- Supplied with the latest Mark 4 Fusion software
- Colourmap measuring technology
- Programmable collimated profile lighting
- Teach and repeat part programming
- Advanced video edge detection
- Digital zoom
- Supplied with stand, rack mount PC and 22" monitor
- Programmable segmented LED surface ring light
- Auto inspection playback
- CNC and Manual models available

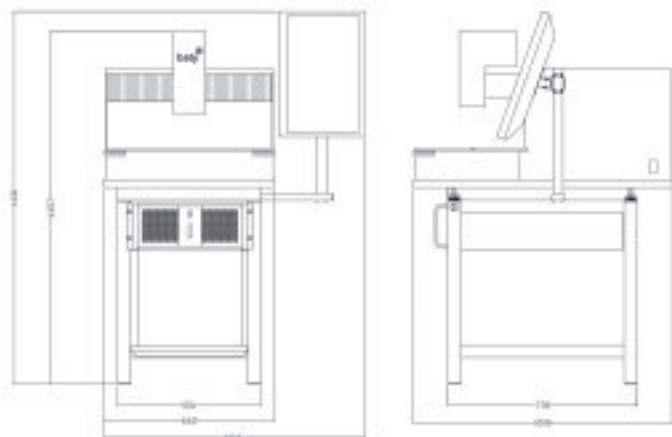

### VUMASTER

Code No	Description
VM-4030-MAN	Manual VuMaster including 22" LCD monitor
VM-4030-CNC	CNC VuMaster including 22" LCD monitor

For more information contact [sales@baty.co.uk](mailto:sales@baty.co.uk) or visit [www.baty.co.uk](http://www.baty.co.uk)

## Baty Vision Systems - Venture Touch

The highly successful Venture Touch range combines both manual and CNC axis that cover two differing stage sizes.

### Venture Touch 3D

This advanced Vision system combines a manually operated X-Y measuring stage with a motorised Z axis. The advantage of this is that the servo motor driven Z axis can provide the all-important autofocus function for Z axis measurement without operator influence.

Suitable for the shop floor, the rugged design features a steel / granite base with fully integrated PC controller running Baty's all new 3 axis touch screen software - Fusion Touch. The full HD touch screen can be mounted on an adjustable arm and the software is arranged in a portrait layout for ease of use.

Fusion Touch software features full geometric functionality so circles, lines, arcs and points can be measured using dedicated tools. Data points are automatically taken along the edge of the feature using Video Edge Detection then all measurements are automatically saved should the inspection need to be replayed for a batch of parts.

All measured features appear in the part view where they can be dimensioned. The dimensional part view that can then be printed or exported to CAD Tolerances are set for each dimension so that the final inspection reports can classify each dimension as a pass or fail.

### Inspection playback

During this process the operator is guided through the inspection routine via the graphical part view. Once the stage has been positioned so that the feature appears in the camera's view, the Video Edge Detection tools take over and measure the feature automatically. If features are on different planes, the Z axis drives under CNC control to the correct position as defined by the original inspection. All lighting and magnification conditions are also recorded and re-created as each feature is visited. The end result is a highly repeatable process with no operator influence.

### Lighting

The programmable LED lighting is also controlled using the touch screen. Segmented surface illumination, co-axial, through the lens and profile lighting conditions which can be adjusted to ensure that the feature edge is perfectly illuminated.



### Standard Fusion Touch System features include:

- 22" HD touch screen monitor
- Motorised autofocus for accurate Z axis measurements
- Fully dimensioned part view
- CAD import / export
- Profile scanning and best fit to CAD master
- SPC batch information including control charts
- Auto output to excel
- 64 LED programmable segmented surface illumination
- Advanced video edge detection
- Heavy duty stage with cross roller rail guides
- TTL light and collimated profile illumination

### Optional

- Steel machine stand with granite top

### Venture Touch

As with all Ventures, a high precision zoom lens is featured as standard. This CNC version has 6 preset zoom positions which provide a magnification range from approx. 30x – 200x\* which can be extended with the use of auxiliary lenses. Each preset position is pre-calibrated enabling the user to quickly select the optimum magnification for each measurement and continue measuring.

### Easy Reporting

In addition to a graphical representation of the measured part, detailed reports can be instantly created showing the feature name, nominal dimension, actual, error, upper and lower limits and a green pass or red fail label for each measured dimension in tabulated format. Geometric tolerance details can also be displayed along with a thumbnail view of the part and batch/customer information. The entire report can be duplicated as an Excel workbook for email.

VENTURE TOUCH	
Code No	Description
VI-2510-Touch	Venture Manual with motorised Z and autofocus, Fusion Touch software, 250 x 125 x 155 X, Y, Z measuring range
VI-3030-Touch-XT	Venture Manual with motorised Z and autofocus, Fusion Touch software, 300 x 300 x 300 X, Y, Z measuring range
VI-Vision-Stand	All steel machine stand with granite top

For more information contact [optical@bowersgroup.co.uk](mailto:optical@bowersgroup.co.uk)

## Baty Vision Systems - Venture 3D CNC

The Venture XT- CNC has Fusion 3D software, a 300mm x 300mm x 200mm XYZ stage and includes a controller and 2 x 19 inch monitors.

Venture CNC models take the power of fusion software one stage further by completely automating the inspection process. Now advanced features like scanning and best fitting can be done quickly without taking up the time of skilled operators.

CNC programming is a simple teach and repeat process. Just measure the part once and a full CNC program is created automatically. The zoom lens can also be controlled so that magnification and auto focus changes are all recorded into the program.

### CNC Functionality

The use of a touch probe is optimised on a CNC system. Measurements from data points taken using the touch probe can be combined with those taken using video edge detection for optimum speed and reduced inspection times.

A probe changer rack can be installed so that probe modules fitted with a variety of pre-calibrated styli can also be used in the same inspection. When a change of stylus is required, the system automatically puts the current probe module back in the rack and picks up the next to continue the inspection process.

When programming using the touch probe, use only the minimum points required to define each element. Then simply edit in the optimum number of points for each element. The new probe path is then automatically created when the program is played, cutting down both programming and inspection time. Alternatively, features can be programmed directly from an imported 3D CAD model.

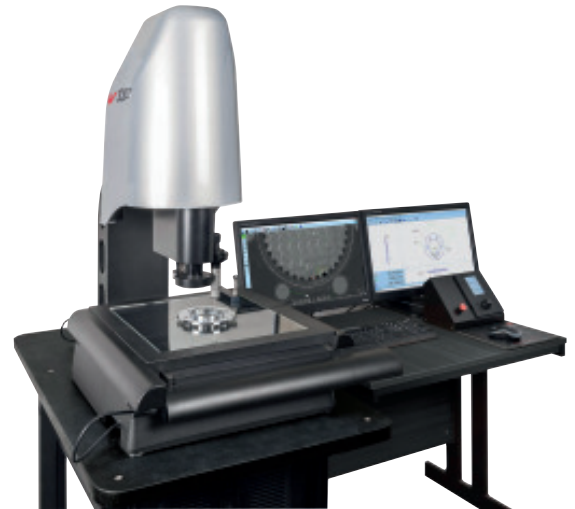

### Standard CNC system features include:

- Teach and Repeat programming
- Programmable segmented LED lighting
- 6.5:1 zoom optics (with optional CNC control)
- Optional 12x zoom optics
- High resolution 0.5µm scales for increased accuracy
- Optional CAD import / export
- Auto program from CAD
- Adding DXF scanning and best fitting
- Fully dimensioned part view
- SPC included
- One click output to Excel™
- Autofocus
- 250mm x 125mm and 300mm x 300mm XY stages available

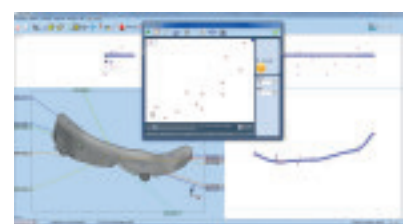
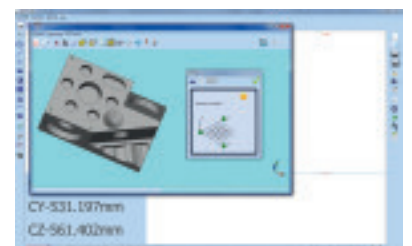
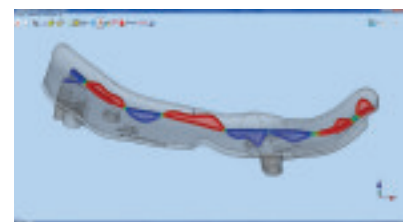

### VENTURE XT-CNC

Code No	Description
VI-3030-CNC-XT	Venture XT CNC with Fusion 3D software, 300mm x 300mm x 200mm stage, incl controller and 2 x 19" monitors
VI-2510-CNC	Venture 2510 CNC with Fusion 3D software, 250mm x 125mm x 155mm stage, incl controller and 2 x 19" monitors
TP-20 Kit	Touch probe kit incl ref ball, module and stylus

For more information contact [sales@baty.co.uk](mailto:sales@baty.co.uk) or visit [www.baty.co.uk](http://www.baty.co.uk)

## Baty Options & Accessories

### CAD

3D CAD models (STEP or IGES) can be imported and are shown in a floating window. After alignment to the CAD model, points are taken anywhere on the part surface and displayed on the CAD model. The points appear colour coded so as to indicate their distance from the nominal surface. These models can be used for off-line programming or CAD comparison.

### CAD Comparison

3D CAD models (STEP or IGES format) can be imported and displayed in a floating window. Following a simple part coordinate alignment to the CAD model, data points can be taken anywhere on the part surface. These data points are then displayed on the CAD model and classified according to their distance from the nominal surface for 3D profile analysis.

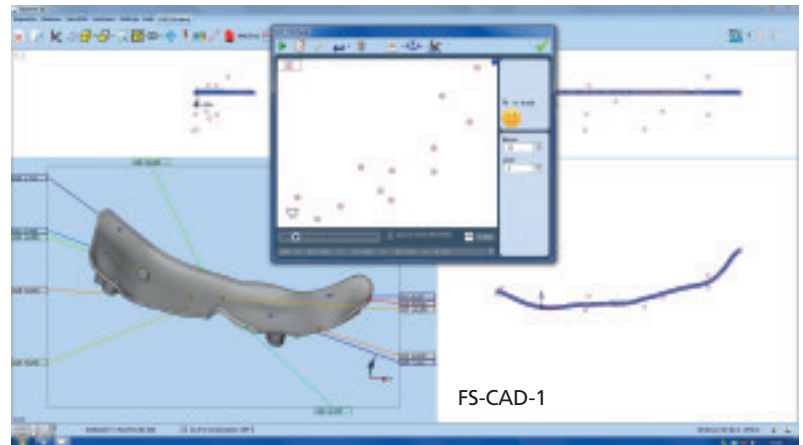

### SA-196

Cast vee blocks and extended centres for the 2510 and 3030 Venture models.

### UFB3030

Universal fixture base provides fixture mounting slots compatible with all projector accessories.

### Vision Stand

Rigid steel stand with granite top and integral PC / controller shelf for Venture 2510 and 3030 models.

### Glass Reference Standard

Calibration standard with nominal diameters for field of view measurement verification and pixel calibration.



SB-A-1371-0163



SA-196-EXT



VI-3030-UFB



VI-Vision-Stand

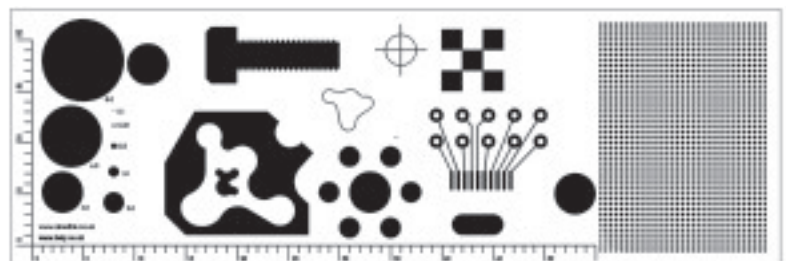

CAL-MAG-2

### VENTURE OPTIONS

Code No	Description
AB3D-CAD-Comp	CAD comparison software
AB3D-CAD-Prog	CAD programming software
SB-A-1371-0163	Probe module change rack - 6 port
SA-196-EXT	Dual vee block and centres
VI-3030-UFB	Universal fixture base
VI-Vision-Stand	All steel machine stand with granite top
CAL-MAG-2	Glass calibration artefact

For more information contact [optical@bowersgroup.co.uk](mailto:optical@bowersgroup.co.uk)

## Baty Vision Systems - Venture Plus

The Venture Plus range includes all of the standard Venture features with a little more... measuring range, that is.

### Large Measurement Volume

The Venture Plus is available in four models:

**VP-6460-CNC** with 640mm x 600mm x 250mm measuring range

**VP-6490-CNC** with 640mm x 900mm x 250mm measuring range

**VP-100100-CNC** with 1000mm x 1000mm x 400mm measuring range

**VP-100150-CNC** with 1000mm x 1500mm x 400mm measuring range

The bridge type construction is all aluminium resulting in low inertia and low thermal mass. Air bearings are used on all axes and a granite Y beam is used for increased accuracy. This ensures that the machine will expand and contract uniformly with temperature changes ensuring minimal distortion and subsequent errors. Ambient temperature can be compensated for within the Fusion software making Venture Plus ideal for use on the shop floor.

### Standard CNC System features include:

- Teach and repeat programming
- Programmable segmented LED lighting
- High resolution 0.5µm scales for increased accuracy
- Optional CAD import / export
- Adding DXF scanning and best fitting
- Fully dimensioned part view
- SPC included
- One click output to Excel™
- Autofocus
- Renishaw TP20 touch probe joint
- Integrated machine stand

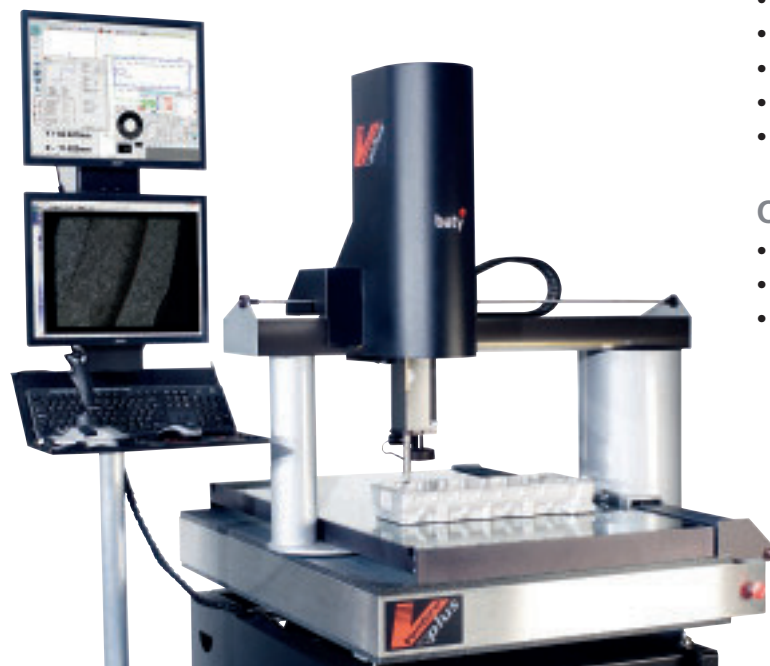

Complete with our standard zoom optics and programmable, segmented LED surface lighting, Venture Plus offers the same level of camera based functionality as every other Venture.

The use of a touch probe is optimised on a CNC system. Measurements from data points taken using the touch probe can be combined with those taken using Video Edge Detection for optimum speed and reduced inspection times.

A probe changer rack can be installed so that probe modules fitted with a variety of pre- calibrated styli can also be used in the same inspection. When a change of stylus is required, the system automatically puts the current probe module back in the rack and picks up the next to continue the inspection process. This functionality can be combined with our sophisticated Edge Detection to offer the ultimate in large format multi-sensing Vision systems - Venture Plus.

### Venture Plus additional features include:

- Rigid, low mass bridge construction
- Integral 6.5:1 CNC zoom optics
- Teach and repeat programming
- Programmable segmented LED lighting
- High resolution 0.5µm scales for increased accuracy
- Optional CAD import / export
- Adding DXF scanning and best fitting
- Fully dimensioned part view
- SPC included
- One click output to Excel™
- Autofocus
- Renishaw TP20 touch probe joint
- Integrated machine stand
- Includes PC controller
- CNC controlled collimated profile lighting
- 250/400mm Z axis measuring range
- Optional automatic temperature compensation

### Options include:

- Multi-function remote joystick with colour touch screen
- 12:1 zoom optics
- Renishaw SP25 scanning probe

## Baty Vision Systems - Venture Plus

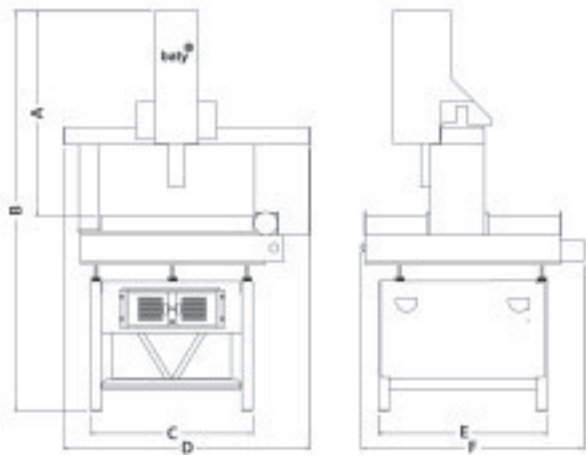

**VP-100100-CNC** with 1000mm x 1000mm x 400mm measuring range

**VP-100150-CNC** with 1000mm x 1500mm x 400mm measuring range



VP-100100-CNC with 1000 x 1000 x 400mm measuring range

### VENTURE PLUS

Code No	Description	Dimn - A	Dimn - B	Dimn - C	Dimn - D	Dimn - E	Dimn - F
VP-6460-CNC	Venture Plus (640 x 600 x 250mm)	950mm	1851mm	750mm	1140mm	783mm	1030mm
VP-6490-CNC	Venture Plus (640 x 900 x 250mm)	950mm	1851mm	750mm	1140mm	1083mm	1330mm
VP-100100-CNC	Venture Plus (1000 x 1000 x 400mm)	1440mm	2250mm	1380mm	1470mm	1350mm	1470mm
VP-100150-CNC	Venture Plus (1000 x 1000 x 400mm)	1440mm	2250mm	1380mm	1470mm	1350mm	1470mm

For more information contact [optical@bowersgroup.co.uk](mailto:optical@bowersgroup.co.uk)



## Fusion Software

Fusion metrology software has been the foundation for Baty's camera based inspection systems for the last decade. The combination of ease of use, advanced edge detection and graphical reporting has established this remarkable software as the standard by which other vision packages are measured.



### Dimensioned Part View

Measured results are displayed in the form of a fully dimensioned drawing. Dimensions within the specified tolerance are shown in green whilst dimensions out of tolerance are shown in red for immediate visual status of the measured part. Geometric tolerances can also be displayed using the standard drawing practice. The final dimensioned part view can then be printed as an engineering drawing with a traditional drawing frame containing company details, customer and part details, date and inspection name.

### SPC Included

Baty Fusion software will also display SPC batch information for multiple components. Information given includes maximum value in batch, minimum value, user definable sigma value, CP and CPK value, mean shift and also plots two different charts of the batch data.

### Easy Reporting

In addition to the graphical representation above, detailed reports can be instantly created showing the feature name, nominal dimension, actual, error, upper and lower limits and a green pass or red fail label for each measured dimension in tabulated format. Geometric tolerance details can also be displayed along with a thumbnail view of the part and batch/customer information. The entire report can be duplicated as an Excel workbook for email.

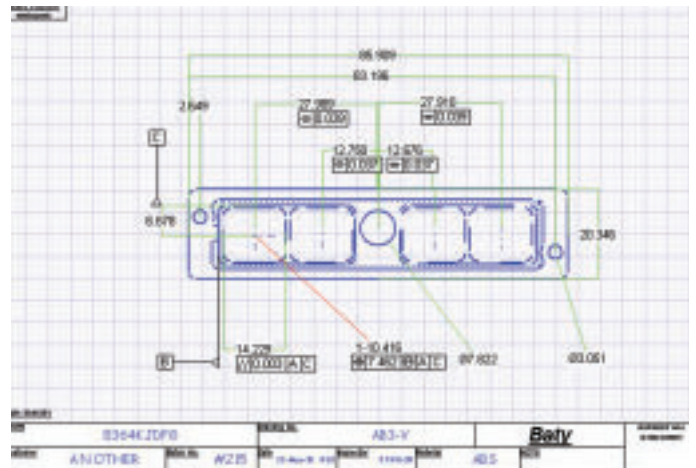
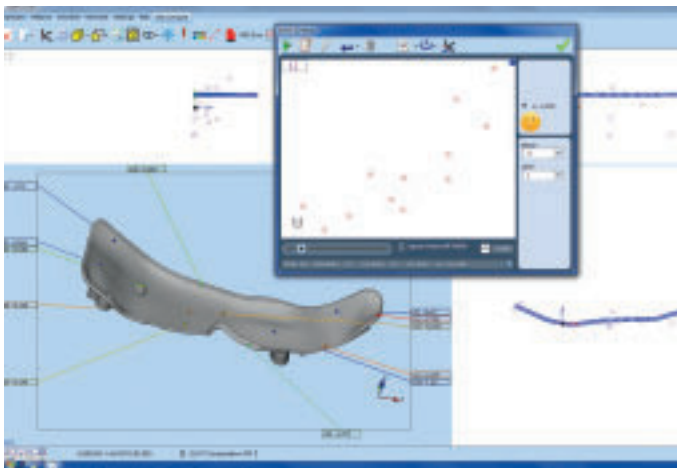

Baty International										
Drawing No.	Customer	Order No.	Material	Date	Inspector	Drawing No.				
8354KJDF0	ANDTHER	W2B	AB3-Y	28-Oct-04 18:50	AD5	8354KJDF0				
Feature	Dimension	Normal	Actual	Error	Upper	Lower	Pass/Fail	Min	Max	Pass/Fail
1. Hole	Ø 10.00	Ø 10.00	Ø 10.00	0.000	Ø 10.00	Ø 10.00	Pass	0.000	0.000	Pass
2. Hole	Ø 10.00	Ø 10.00	Ø 10.00	0.000	Ø 10.00	Ø 10.00	Pass	0.000	0.000	Pass
3. Hole	Ø 10.00	Ø 10.00	Ø 10.00	0.000	Ø 10.00	Ø 10.00	Pass	0.000	0.000	Pass
4. Hole	Ø 10.00	Ø 10.00	Ø 10.00	0.000	Ø 10.00	Ø 10.00	Pass	0.000	0.000	Pass
5. Hole	Ø 10.00	Ø 10.00	Ø 10.00	0.000	Ø 10.00	Ø 10.00	Pass	0.000	0.000	Pass
6. Hole	Ø 10.00	Ø 10.00	Ø 10.00	0.000	Ø 10.00	Ø 10.00	Pass	0.000	0.000	Pass
7. Hole	Ø 10.00	Ø 10.00	Ø 10.00	0.000	Ø 10.00	Ø 10.00	Pass	0.000	0.000	Pass
8. Hole	Ø 10.00	Ø 10.00	Ø 10.00	0.000	Ø 10.00	Ø 10.00	Pass	0.000	0.000	Pass
9. Hole	Ø 10.00	Ø 10.00	Ø 10.00	0.000	Ø 10.00	Ø 10.00	Pass	0.000	0.000	Pass
10. Hole	Ø 10.00	Ø 10.00	Ø 10.00	0.000	Ø 10.00	Ø 10.00	Pass	0.000	0.000	Pass
11. Hole	Ø 10.00	Ø 10.00	Ø 10.00	0.000	Ø 10.00	Ø 10.00	Pass	0.000	0.000	Pass
12. Hole	Ø 10.00	Ø 10.00	Ø 10.00	0.000	Ø 10.00	Ø 10.00	Pass	0.000	0.000	Pass
13. Hole	Ø 10.00	Ø 10.00	Ø 10.00	0.000	Ø 10.00	Ø 10.00	Pass	0.000	0.000	Pass
14. Hole	Ø 10.00	Ø 10.00	Ø 10.00	0.000	Ø 10.00	Ø 10.00	Pass	0.000	0.000	Pass
15. Hole	Ø 10.00	Ø 10.00	Ø 10.00	0.000	Ø 10.00	Ø 10.00	Pass	0.000	0.000	Pass
16. Hole	Ø 10.00	Ø 10.00	Ø 10.00	0.000	Ø 10.00	Ø 10.00	Pass	0.000	0.000	Pass
17. Hole	Ø 10.00	Ø 10.00	Ø 10.00	0.000	Ø 10.00	Ø 10.00	Pass	0.000	0.000	Pass
18. Hole	Ø 10.00	Ø 10.00	Ø 10.00	0.000	Ø 10.00	Ø 10.00	Pass	0.000	0.000	Pass
19. Hole	Ø 10.00	Ø 10.00	Ø 10.00	0.000	Ø 10.00	Ø 10.00	Pass	0.000	0.000	Pass
20. Hole	Ø 10.00	Ø 10.00	Ø 10.00	0.000	Ø 10.00	Ø 10.00	Pass	0.000	0.000	Pass

## Fusion Software

### Video Edge Detection

Video Edge Detection (VED) ensures a repeatable result without relying on the skill of the operator. Hundreds of data points can be taken in an instant to calculate standard geometric features. Standard VED tools include arc, circle, line, point, focus and curve.

### Image Stitching and Profile Scanning

A camera image can be taken and stored every time the XY stage is paused. These images may be "stitched" together to allow the user to zoom out and view the entire component in the camera image view. Imported dxf files may be used as overlays which can be super imposed on top of the stitched image, providing a visual comparison of the entire part to the tolerance bands shown on the dxf. If a profile measurement is required the curve tool can be used to automatically trace the profile of the part. The resulting data-point cloud can then be viewed both in the part view, for reporting, as well as the stitched camera image. A profile dimension can easily be added to define the best fit profile error. Image stitching can also be used to quickly grab all of the features of a large 2D component. A CNC inspection routine can then be created by simply clicking on the feature to be measured using the "one click" feature or "all features in an area" tools.

### Touch Probe Compatible

Fusion metrology software is ready to accept touch probe measurements as well as optical and camera based. Offsets for each measuring system can be calculated enabling you to use a combination of non-contact measurements in the same inspection. An optional probe storage rack can also be used to allow automatic probe changes mid program. For touch probe scanning applications, Renishaw's SP25 scanning probe option can be specified.

### CNC Operation

The CNC option enables fully automatic part inspection with teach and repeat programming and manual joystick control. Parts can be palletised for batch inspection and reports are generated automatically.

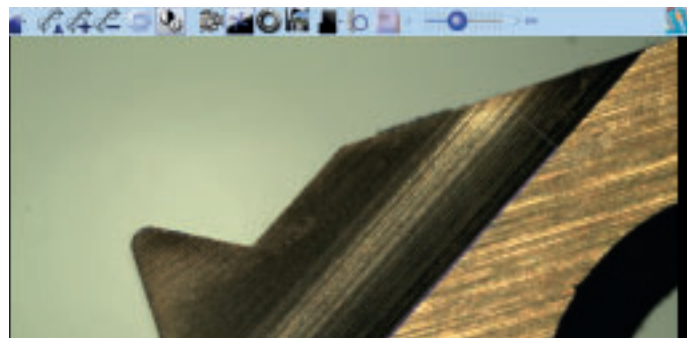
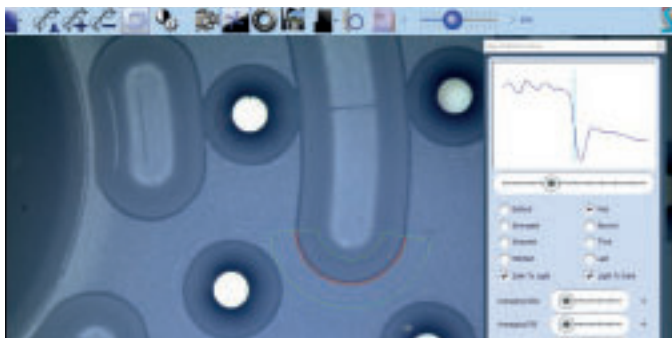

### CAD Option

Allows measurement data points taken anywhere on the part surface to be compared to a 3D IGES or STEP CAD model.

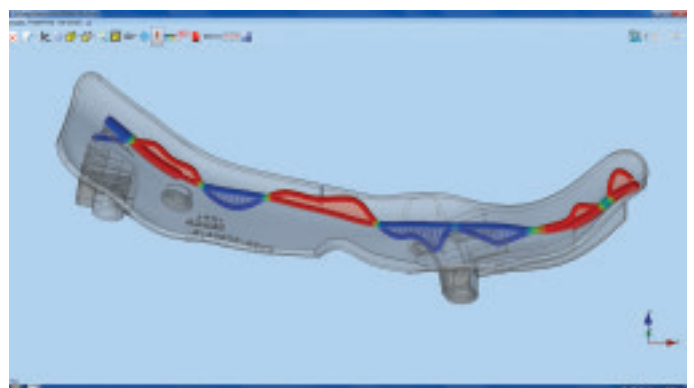
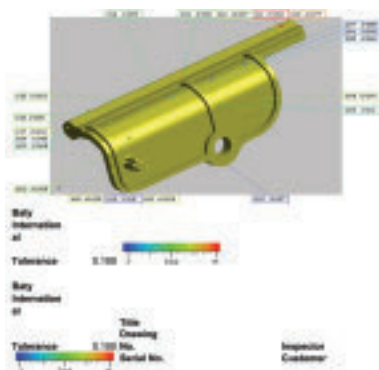

## Flexmaster Fixtures

Flexmaster components introduce new technology. Our self-wedging clamps offer near zero clamping force. Sliding t-nut tooling blocks provide an infinite variety of fixture solutions.

Even the corner joiners for our frame are dual purpose, providing ridges that allow backlighting to illuminate edges for inspection.

### Fixture frame assembly, includes the following:

- 4 off linear slide-frames with t-slots, and laser marked reference scales
- 4 off ridged two-way T-nuts for corner joining and part location
- 4 off sliding hold-down brackets with slots for 2 axis adjustment to mount t-slot frames to venture stage frame

### Fasteners

- 30 off stainless grub screws
- 3 off long T-nuts
- 6 off short T-nuts
- 2 off T-nuts with machined vee in end
- 12 off locknut with threaded ID.  
(For use with clamp rods, thumbscrew, and spherical locator pin)

### Clamps and Rods

- 2 off narrow 'soft-touch' self-wedging tail-spring clamp
- 2 off wide 'soft-touch' self-wedging tail-spring clamp
- 2 off self-wedging V-clamp
- 2 off ridged corner locator clamp
- 3 off stainless clamp rod.  
(Use with locknut to attach rods to slideframe, for self-wedging clamps)
- 3 off stainless clamp rod
- 2 off stainless clamp rod

### Locators

- 3 off sliding tool blocks with threaded holes for vertical clamp and adjustment
- 4 off adjustable rest button, stainless, spherical top
- 2 off additional ridged two-way t-nuts for part location
- 1 off case

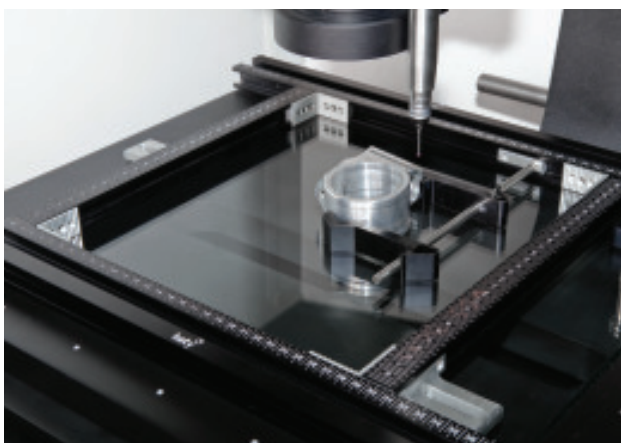
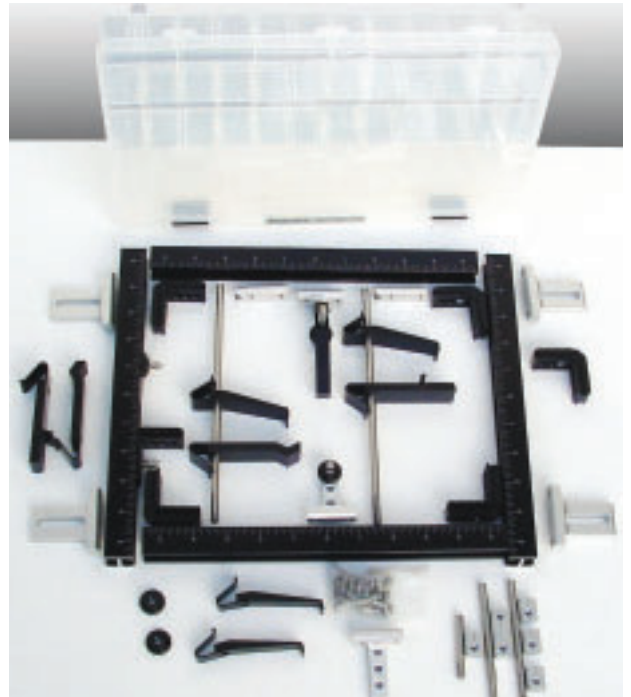

## Baty Vision Systems - Technical Specification

### TECHNICAL SPECIFICATION

	MANUAL SYSTEMS		SEMI AUTOMATIC
	VM-4030 VuMaster	VI-2510 Venture	Venture-Touch-3030
X Y Z measuring range (mm)	400 x 300	250 x 125 x 165	300 x 300 x 300
Workstage area (mm)	420 x 320	414 x 262	464 x 462
Max workpiece load (kg)	25	25	25
Drive type	Manual	Manual	Manual XY CNC Z
Bearings	Air bearings	Cross roller rail guide	Cross roller rail guide
Camera type	2048 x 1590 pixel colour USB2 camera with 8 x 9mm chip and dynamic latch		
Optics / lighting	Fixed objective telecentric lens with programmable LED lighting		6.5:1 detent zoom lens. Fully programmable software controlled white LED segmented surface lighting head with understage and through the lens (TTL) lighting as standard
Resolution	0.001mm	0.0005mm	
Accuracy	7.5µm	2+L / 100	
Max field of view (FOV)	12mm	16mm*	
Magnification	20x 350x		Optical zoom ratio 27x - 175x on 17" monitor with digital zoom enhancement to over 1200x
Touch probe option available	No	Yes	No
Probe type	N/A	Renishaw TP20	N/A
Change rack compatible?	N/A	N/A	N/A

\*using optional 0.5x adapter lens

### CNC SYSTEMS

	VM-4030 VuMaster	VI-2510 Venture	VI-3030 Venture XT CNC	VP-6460 Venture Plus	VP-6490 Venture Plus	VP-100150 Venture Plus
X Y Z measuring range (mm)	400 x 300	250 x 125 x 165	300 x 300 x 200	640 x 600 x 250	640 x 900 x 250	1000 x 1500 x 400
Workstage area (mm)	420 x 320	414 x 262	464 x 462	700 x 940	700 x 1240	1050 x 1850
Max workpiece load (kg)	25	25	25	75	75	75
Drive type	CNC / handwheel	CNC / joystick	CNC / joystick	CNC / joystick	CNC / joystick	CNC / joystick
Bearings	Air bearings	Cross roller rail guide	Cross roller rail guide	Air bearings	Air bearings	Air bearings
Max drive speed	100mm / sec	200mm / sec	200mm / sec	350mm / sec	350mm / sec	350mm / sec
Camera type	2048 x 1590 pixel colour USB2 camera with 8 x 9mm chip and dynamic latch					
Optics / lighting	Fixed objective telecentric lens with programmable LED lighting	6.5:1 CNC zoom lens. Fully programmable software controlled white LED segmented surface lighting head with understage and through the lens (TTL) lighting as standard				
Optional		12:1 CNC zoom lens option for increased FOV	12:1 CNC zoom lens option for increased FOV	12:1 CNC zoom lens option for increased FOV	12:1 CNC zoom lens option for increased FOV	12:1 CNC zoom lens option for increased FOV
Resolution	0.001mm	0.0005mm	0.0005mm	0.0005mm	0.0005mm	0.0005mm
Accuracy	7.5µm	2+L / 100	2+L / 100	2.4 + 0.4 / 100 Volumetric	2.4 + 0.4 / 100 Volumetric	3.8 + 0.4 / 100 Volumetric
Max field of view (FOV)	12mm	16mm*	16mm*	16mm*	16mm*	16mm*
Magnification			20x 350x			
Touch probe option available	No	Yes	Yes	Yes	Yes	Yes
Probe type	N/A	Renishaw TP20	Renishaw TP20	Renishaw TP20	Renishaw TP20	Renishaw TP20
Optional	N/A	Renishaw SP25 scanning probe	Renishaw SP25 scanning probe	Renishaw SP25 scanning probe	Renishaw SP25 scanning probe	Renishaw SP25 scanning probe
Change rack compatible?	N/A	Yes	Yes	Yes	Yes	Yes

\*using optional 0.5x adapter lens

## Reprorubber - Metrology Grade Casting Material

Reprorubber offers numerous advantages over other hard-copy replicating materials:

- Quick casting – zero shrinkage
- No release agent required – will not stick to part
- Surface finish replication is exact with excellent optical properties easily checked on an optical comparator or video inspection machine
- Copies can be re-copied from original mould
- Replicas are permanent – will not leach out, ooze out, or gas out
- No more 16 hour cure time as with RTV silicones
- More accurate than all other RTV compounds

### Original Reprorubber® Thin Pour - Final Colour: LIGHT GREEN

For internal-shape applications where a thin pour will completely fill the cavity without voids. A complete replica casting is quickly formed.

- Manipulation time is approx 2 minutes and cure time is approximately 10 minutes
- Start to finish: approximately 12 minutes
- Kits include graduated mixing cups, wooden spatulas and instructions

### Original Reprorubber® Quick Setting Putty - Final Colour: LIGHT BLUE

Roll two equal-sized balls of catalyst putty and base putty and simply knead them together like dough. Excellent for external shapes.

Simply spread over master pushing down with fingers and wait for cure 8-10minutes. Manipulation time is 1 to 2 minutes. Therefore 12 minutes start to finish.

You can also cast internal shapes and cavities but some pressure should be applied such as a weighted object on top.

### New Reprorubber® Orange – Medium Body Pre-filled Cartridges - Final Colour: ORANGE

New Medium Body (Medium Viscosity – Medium Durometer) casting material ideal for both internal and external applications. Disposable pre-filled dual barrel 50ml cartridges can quickly dispense casting material utilising the REPRO-MIX II Gun System.

- Mix time: 15-30 seconds and cure time is 5-6 minutes
- Start to finish: 6-8 minutes

### Quick Dispense Cartridge System Kit

Contains everything you need to easily create highly accurate, zero shrinkage replicas.

Each kit includes 1 each:

- Reprorubber II reusable dispensing gun
- 6 each 50ml pre-filled Reprorubber disposable cartridges
- 15 disposable mixing nozzles
- 2 micro injector snap-on nozzles
- Deluxe fitted carrying case



## Reprorubber - Metrology Grade Casting Material

### Applications - You can take impressions of:

- All metals
- Non metals
- Paper or cardboard items
- Wood, marble etc
- All plastics
- Rubber
- Ceramic and glass items

### Other Uses Include:

- Prototypes of rubber type components such as gaskets, washers, etc
- Making joints where flexibility is required
- As a mask for high temperature plasma spray of metallic coatings
- Fixturing where semi-rigid structure is desired

### Physical advantages over the hard-copy replicas:

- Replica is easy to remove – even if they are in under cuts or grooves
- Cross-sectioning of replica is easily accomplished with a knife or razor
- It can then be checked on an optical comparator or microscope
- Surface finish replication is exact with excellent optical properties
- Reprorubber copies can be re-copied (copy from a 'female mould' yields a male-shaped replica)
- Replicas are permanent – will not leach or ooze out nor gas out
- No more 16 hour cure time as with RTV silicones
- More accurate than all other RTV compounds
- Reprorubber putty will withstand up to 600°F (or more)

	REPRORUBBER THIN POUR 15-30 seconds	REPRORUBBER MEDIUM BODY ORANGE 15-30 seconds	REPRORUBBER QUICK SETTING PUTTY Approximately 1 minute
Working Time (Manipulation Time)	2 minutes	2.5 minutes	1-2 minutes (from beginning of mix)
Setting Time (at room temperature)	10-15 minutes	5-6 minutes	8-10 minutes
Permanent Deformation	0.2%	0.3%	0.3%
Dimensional Stability	less than 0.50%	less than 0.40%	less than 0.25%
Tear Strength	44 pounds per sq. inch	300 pounds per sq. inch	105 pounds per sq. inch
Elongation	60% at break	70% at break	6.3% at break
Durometer (Shore A-2)	30 (at 15 minutes)	40 (at 10 minutes)	50 (at 7 minutes)
Temperature Stability	1 week @ 23°C (72°F)	1 week @ 23°C (72°F)	1 week @ 23°C (72°F)
Detail Reproduction	EXCELLENT	EXCELLENT	EXCELLENT

### REPRORUBBER

Code No	Description
---------	-------------

#### Ordering Complete Kits:

16300	Reprorubber Thin Pour (Green) Quick Dispense Cartridge System Kit Complete
16305	Reprorubber Orange (Medium Body) Quick Dispense Cartridge System Kit Complete
16309	Reprorubber Combo Kit Quick Dispense Cartridge System Kit, Includes 3 each Thin Pour & 3 each Orange

#### Ordering Original Mix Your Own Kits:

##### Original Reprorubber® Thin Pour - Final Colour: LIGHT GREEN

16116	Thin Pour 130ml Mix Your Own Trial Kit - Final Colour: Light Green
16135	Thin Pour 380ml Mix Your Own Kit - Final Colour: Light Green
16137	Case of 10 each 380ml Mix Your Own Kits - Final Colour: Light Green

#### Ordering Original Mix Your Own Kits:

##### Original Reprorubber® Quick Setting Putty - Final Colour: LIGHT BLUE

16129	220ml Trial Quick Setting Putty Mix Your Own Kit - Final Colour: Light Blue
16130	1 3/4 lb (520ml) Introductory Mix Your Own Kit - Final Colour: Light Blue
16131	7lb (2150ml) Economy Mix Your Own Kit - Final Colour: Light Blue

#### System Refills

16301	Reprorubber Thin Pour (Green) 50ml Cartridge, 1 each
16302	Reprorubber Thin Pour (Green) 50ml Cartridges, 6 pack
16306	Reprorubber Orange (Medium Body) 50ml Cartridge, 1 each
16307	Reprorubber Orange (Medium Body) 50ml Cartridges, 6 pack
16311	Repro-Mix II Dispensing Gun (reusable)
16313	Repro-Mix II Helix Mixing Nozzles, 15 Pack
16316	Repro-Mix II Helix Mixing Nozzles, 100 Pack
16315	Quick Dispense Cartridge System Fitted Case (without contents)
16314	Micro Injector Snap-On Nozzle, Pack of 15



16301



16306

For more information contact [optical@bowersgroup.co.uk](mailto:optical@bowersgroup.co.uk)

## Venture XT

Baty International has been in business since 1932 and in 2018 unveiled the Venture XT, a high precision contact and non-contact hybrid machine. The Venture XT along with Baty's other machines are still manufactured in Sussex, England to this day in accordance with ISO 9001:2008.

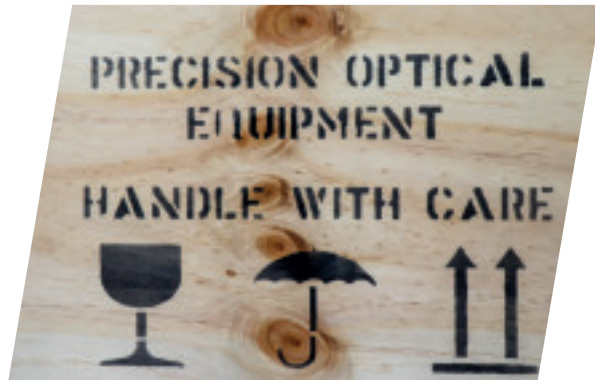
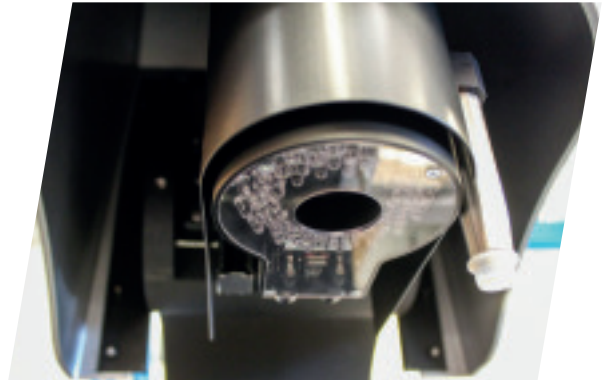



**BOWERS GROUP**



**UK Sales / Customer Service**

**Bowers Group**

Unit 3, Albany Court, Albany Park, Camberley, Surrey GU16 7QR

Tel: 08708 50 90 50 Fax: 08708 50 90 60

Email: [sales@bowersgroup.co.uk](mailto:sales@bowersgroup.co.uk)

Website: [www.bowersgroup.co.uk](http://www.bowersgroup.co.uk)